

A Compact Dynamic Model for Household Vapor Compression Refrigerated Systems

S.S.Prabhakar¹, M.Mastanaih²

**(PG Scholer, Department of mechanical Engineering, Dr.Samuel George institute of engineering and technology, Markapur, AP, India) Email: royaleng.siva@gmail.com*

*** (Professor, Department Mechanical Engineering, Dr.Samuel George institute of engineering and technology, Markapur,AP,India)*

ABSTRACT: Refrigeration is a process in which work is done to move heat from one location to another. The work of heat transport is traditionally driven by mechanical work, but can also be driven by heat, magnetism, electricity, laser, or other means. Refrigeration has many applications, including, but not limited to: household refrigerators, industrial freezers, cryogenics, and air conditioning. Heat pumps may use the heat output of the refrigeration process, and also may be designed to be reversible, but are otherwise similar to refrigeration units.

In this thesis a compact model of house hold refrigerator, refrigeration system is designed and modeled in 3D modeling software Pro/Engineer. The refrigeration system consists of condenser, evaporator, compressor and expansion valve. The refrigerant used most nowadays is HFC-134a.

In this thesis, it is replaced with HCFC, HFC-152A, 404R. The present used material for condenser is copper, in this thesis it is replaced with aluminum alloy 6061 and aluminum. Thermal analysis is done on the condenser, compressor and evaporator by changing the materials and refrigerants. Thermal analysis is done in Ansys.

Keywords: Refrigeration, Heat pumps, Pro/Engineer, HCFC, HFC-152A, 404R.

I. INTRODUCTION

A refrigerator (colloquially fridge) is a common household appliance that consists of a thermally insulated compartment and a heat pump (mechanical, electronic, or chemical) that transfers heat from the inside of the fridge to its external environment so that the inside of the fridge is cooled to a temperature below the ambient temperature of the room. Refrigeration is an essential food storage technique in developed countries. Lower temperatures in a confined volume lowers the reproduction rate of bacteria, so the refrigerator reduces the rate of spoilage. A refrigerator maintains a temperature a few degrees above the freezing point of water. Optimum temperature range for perishable food storage is 3 to 5 °C (37 to 41 °F). A similar device that maintains a temperature below the freezing point of water is called a freezer. The refrigerator replaced the icebox, which was a common household appliance for almost a century and a half prior. For this reason, a refrigerator is sometimes referred to as an icebox in American usage. Refrigeration is the process of maintaining temperature in a space lower than the surroundings. In this process heat is removed from the source at low temperature and thrown out to the source at higher temperature. Refrigeration is the process of heat transfer against the natural flow of heat which is from high temperature to low temperature. This heat is carried by a fluid, usually the Freon gas.

II. VAPOR-COMPRESSION REFRIGERATION

Vapor-compression refrigeration is one of the many refrigeration cycles and is the most widely used method for air-conditioning of buildings and automobiles. It is also used in domestic and commercial refrigerators, large-scale warehouses for chilled or frozen storage of foods and meats, refrigerated trucks and railroad cars, and a host of other commercial and industrial services. Oil refineries, petrochemical and chemical processing plants, and natural gas processing plants are among the many types of industrial plants that often utilize large vapor-compression refrigeration systems. Refrigeration may be defined as lowering the temperature of an enclosed space by removing heat from that space and transferring it elsewhere. A device that performs this function may also be called an air conditioner, refrigerator, air source heat pump, water source heat pump, geo thermal heat pump or chiller (*heat pump*).

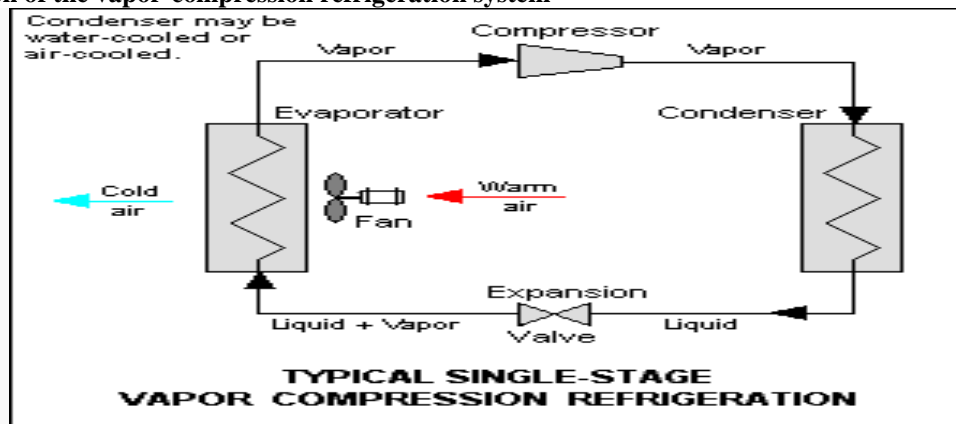
Description of the vapor-compression refrigeration system**Figure 1: Vapor compression refrigeration**

The vapor-compression uses a circulating liquid refrigerant as the medium which absorbs and removes heat from the space to be cooled and subsequently rejects that heat elsewhere. Figure 1 depicts a typical, single-stage vapor-compression system. All such systems have four components: a compressor, a condenser, a thermal expansion valve (also called a throttle valve or metering device), and an evaporator. Circulating refrigerant enters the compressor in the thermodynamic state known as saturated vapor and is compressed to a higher pressure, resulting in a higher temperature as well. The hot, compressed vapor is then in the thermodynamic state known as a superheated vapor and it is at a temperature and pressure at which it can be condensed with either cooling water or cooling air. That hot vapor is routed through a condenser where it is cooled and condensed into a liquid by flowing through a coil or tubes with cool water or cool air flowing across the coil or tubes. This is where the circulating refrigerant rejects heat from the system and the rejected heat is carried away by either the water or the air (whichever may be the case). The condensed liquid refrigerant, in the thermodynamic state known as a saturated liquid, is next routed through an expansion valve where it undergoes an abrupt reduction in pressure. That pressure reduction results in the adiabatic flash evaporation of a part of the liquid refrigerant. The auto-refrigeration effect of the adiabatic flash evaporation lowers the temperature of the liquid and vapor refrigerant mixture to where it is colder than the temperature of the enclosed space to be refrigerated. The cold mixture is then routed through the coil or tubes in the evaporator. A fan circulates the warm air in the enclosed space across the coil or tubes carrying the cold refrigerant liquid and vapor mixture. That warm air evaporates the liquid part of the cold refrigerant mixture. At the same time, the circulating air is cooled and thus lowers the temperature of the enclosed space to the desired temperature. The evaporator is where the circulating refrigerant absorbs and removes heat which is subsequently rejected in the condenser and transferred elsewhere by the water or air used in the condenser. To complete the refrigeration cycle, the refrigerant vapor from the evaporator is again a saturated vapor and is routed back into the compressor.

III. REFRIGERANTS

"Freon" is a trade name for a family of haloalkane refrigerants manufactured by DuPont and other companies. These refrigerants were commonly used due to their superior stability and safety properties: they were not flammable at room temperature and atmospheric pressure, nor obviously toxic as were the fluids they replaced, such as sulfur dioxide. Haloalkanes are also an order(s) of magnitude more expensive than petroleum derived flammable alkanes of similar or better cooling performance. Unfortunately, chlorine- and fluorine-bearing refrigerants reach the upper atmosphere when they escape. In the stratosphere, CFCs break up due to UV radiation, releasing their chlorine free radicals. These chlorine free radicals act as catalysts in the breakdown of ozone through chain reactions. One CFC molecule can cause thousands of ozone molecules to break down. This causes severe damage to the ozone layer that shields the Earth's surface from the Sun's strong UV radiation, and has been shown to lead to increased rates of skin cancer. The chlorine will remain active as a catalyst until and unless it binds with another particle, forming a stable molecule. CFC refrigerants in common but receding usage include R-11 and R-12. Newer refrigerants with reduced ozone depletion effect such as HCFCs (R-22, used in most homes today) and HFCs (R-134a, used in most cars) have replaced most CFC use. HCFCs in turn are being phased out under the Montreal Protocol and replaced by hydrofluorocarbons (HFCs), such as R-410A, which lack chlorine. However, CFCs, HCFCs, and HFCs all have large global warming potential. Newer refrigerants are currently the subject of research, such as supercritical carbon dioxide, known as R-744. These have similar efficiencies compared to existing CFC and HFC based compounds, and have many orders of magnitude lower global warming potential.

A simple vapor compression refrigeration system consists of the following equipments:

- i) Compressor ii) Condenser iii) Expansion valve iv) Evaporator.

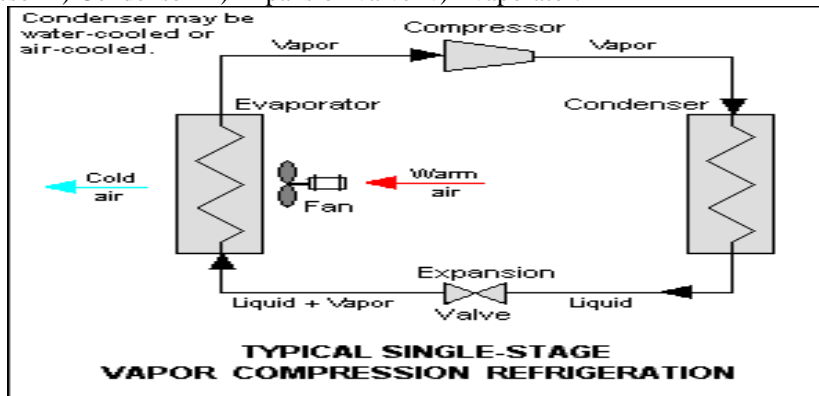

Model of Refrigeration System Of Refrigerator

Compressor

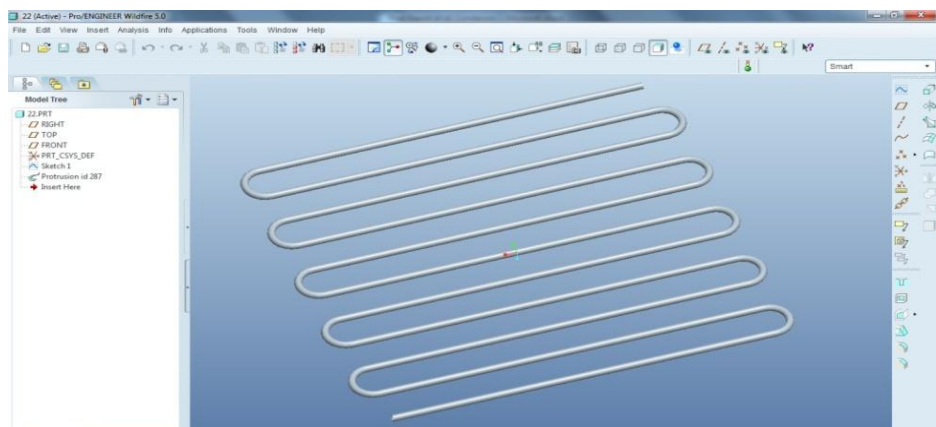
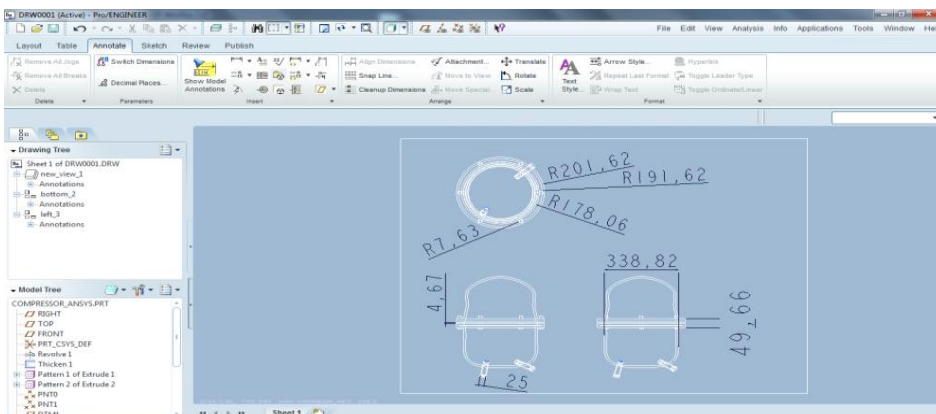
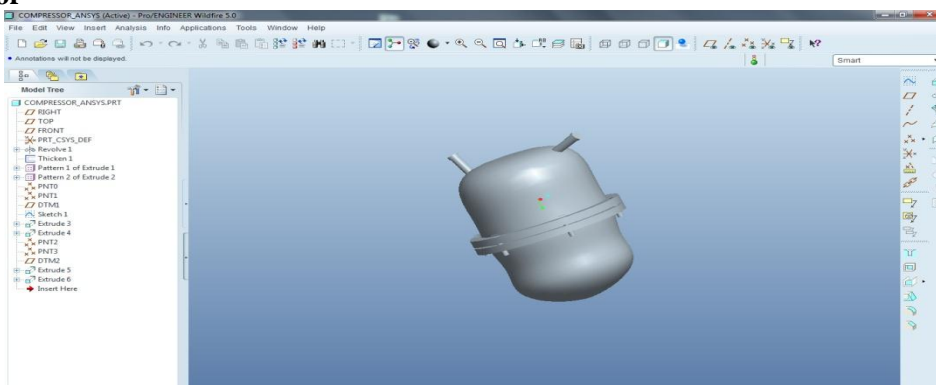

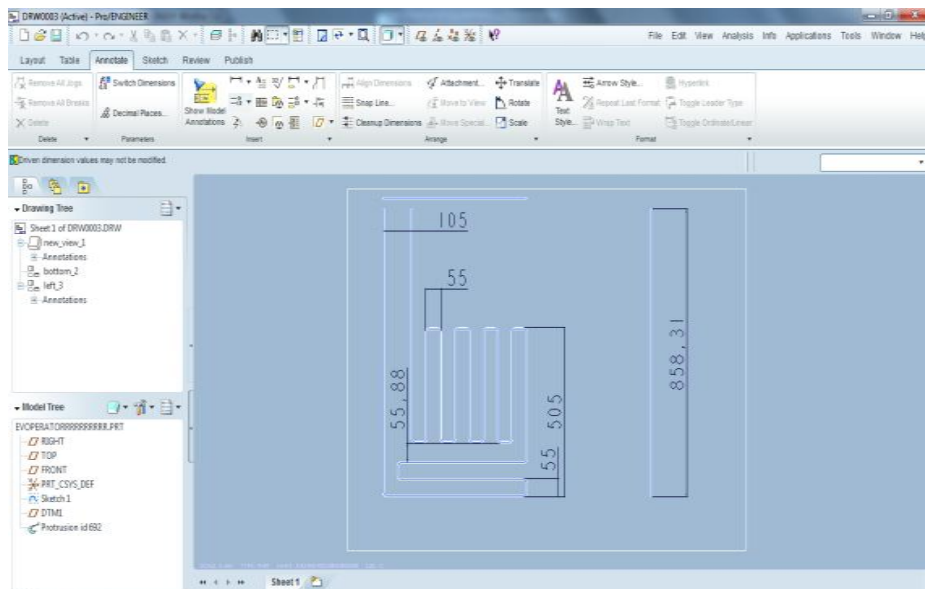
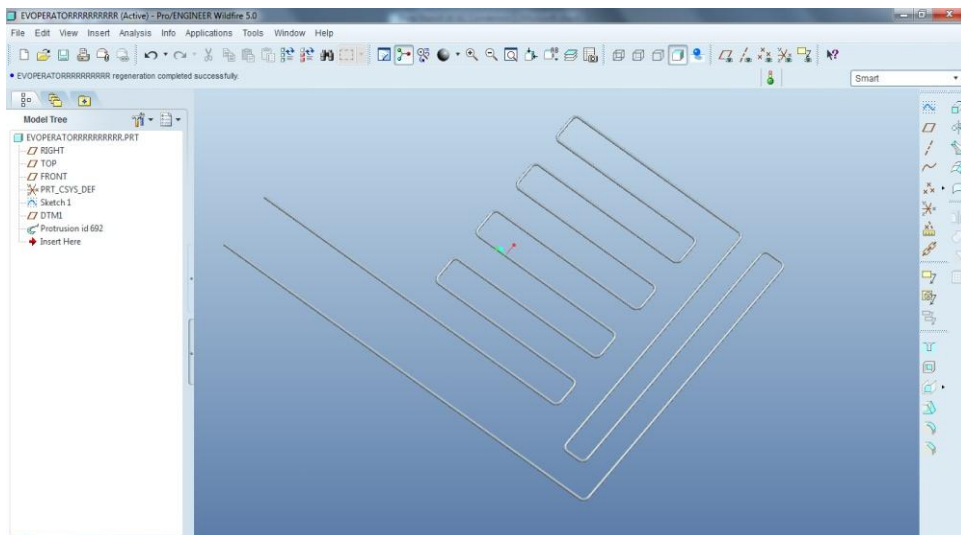
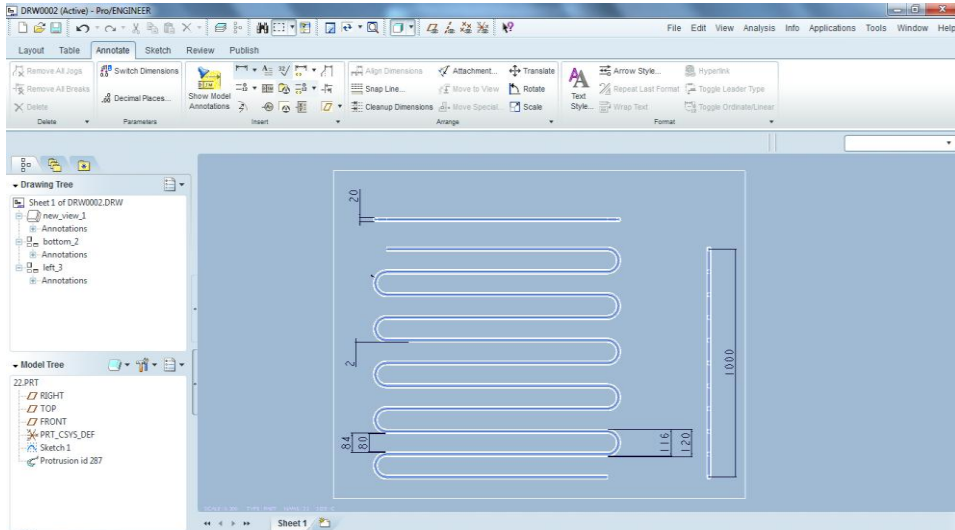

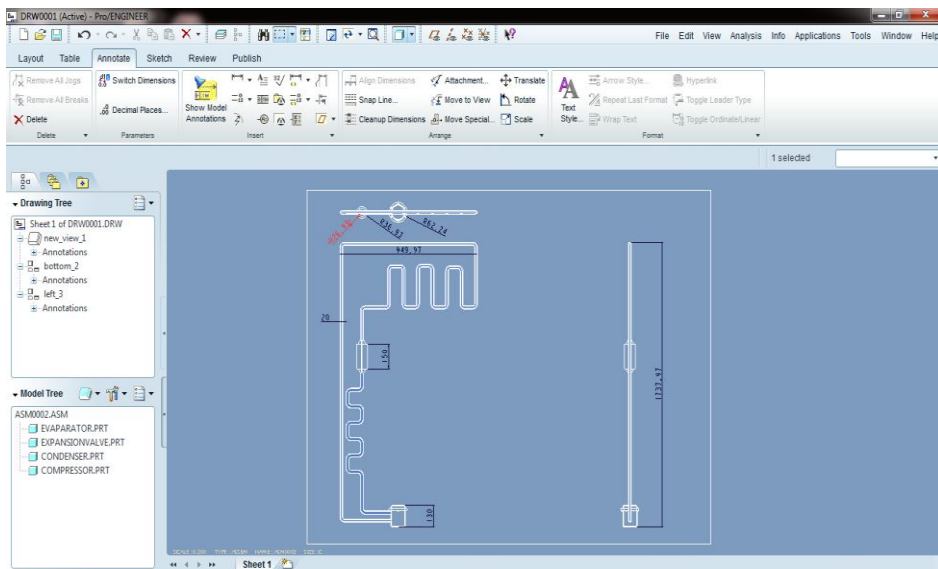
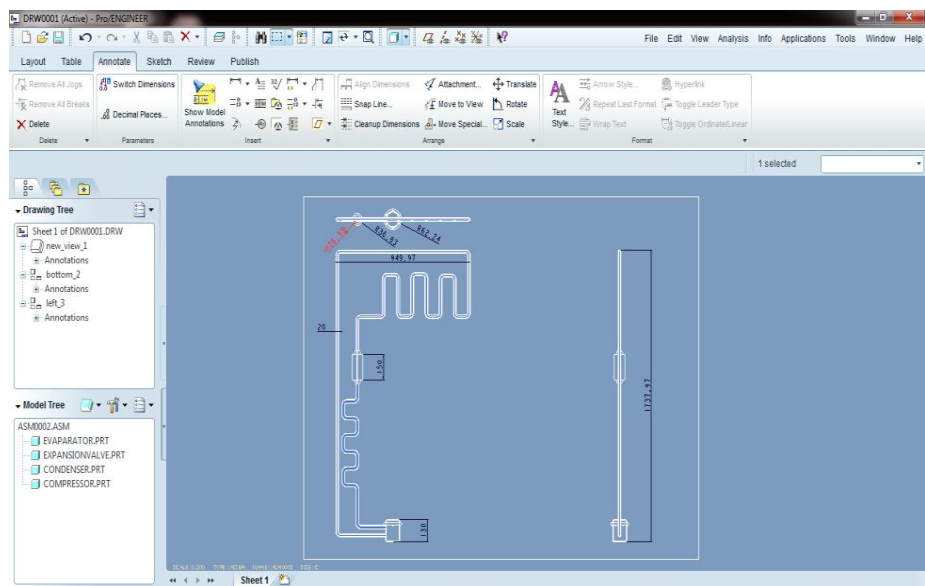
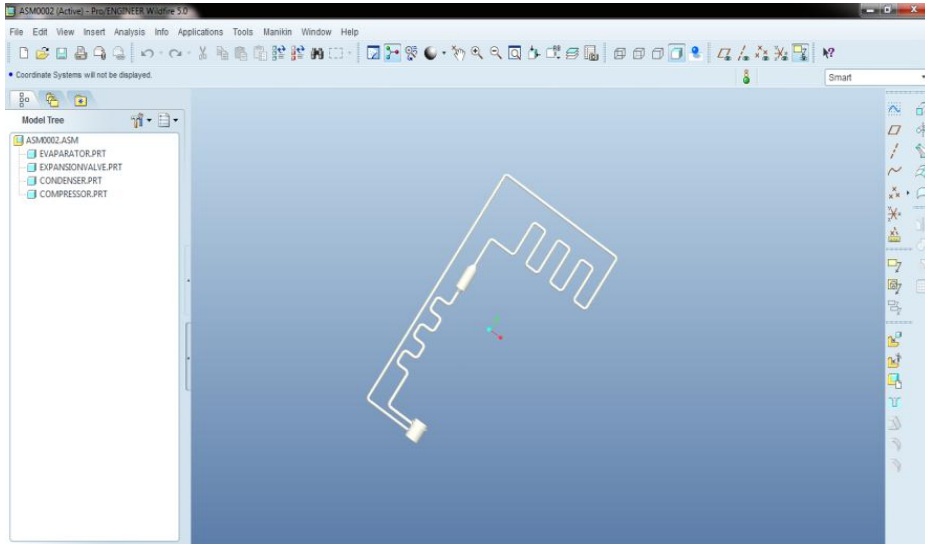

IV. PROCEDURE FOR ANSYS ANALYSIS

Static analysis is used to determine the displacements, stresses, strains and forces in structures or components due to loads that do not induce significant inertia and damping effects. Steady loading in response conditions are assumed. The kinds of loading that can be applied in a static analysis include externally applied forces and pressures, steady state inertial forces such as gravity or rotational velocity imposed (non zero) displacements, temperature (for thermal strain). A static analysis can be either linear or non linear. In our present work we are going to consider linear static analysis.

The procedure for static analysis consists of these main steps:

- Building the model
- Obtaining the solution.
- Reviewing the results.

V. THERMAL ANALYSIS OF CONDENSER

HCFC REFRIGERANT ALUMINUM

File >import>IGES>ok>browse>select file>ok

Preferences>select thermal>ok

Post processor>material properties>material models

Used materials for condenser

Thermal conductivity=210w/mk

Specific heat=900J/Kg.k

Density=269Kg/m³

Imported model

Meshing>mesh tool>smart sizes on> mesh>ok

Meshed model

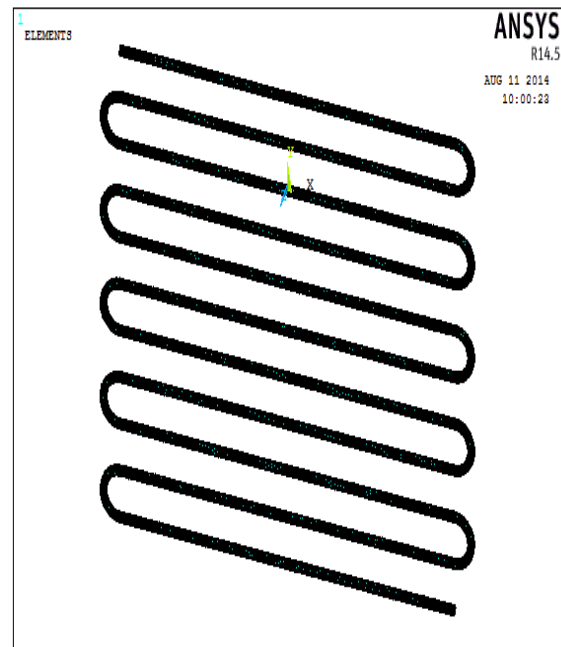
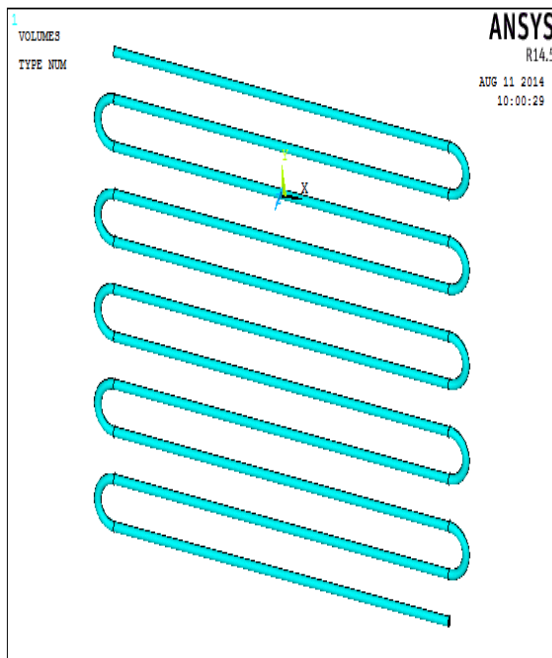

Loads>define loads>apply>thermal>temperature>select temperature area>ok>enter temperature value>313k>ok

Convection>on areas>select convection area>enter film coefficient value=0.024w/m²

Bulk temperature value=303k

Solution>solve>current Ls>ok

General post processor>plot results>counter plot>nodal solution>dof solution>nodal temperature>ok

NODAL TEMPERTATURE

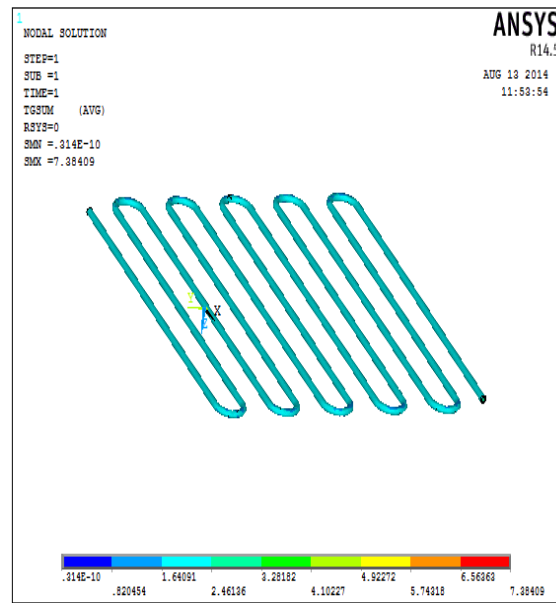
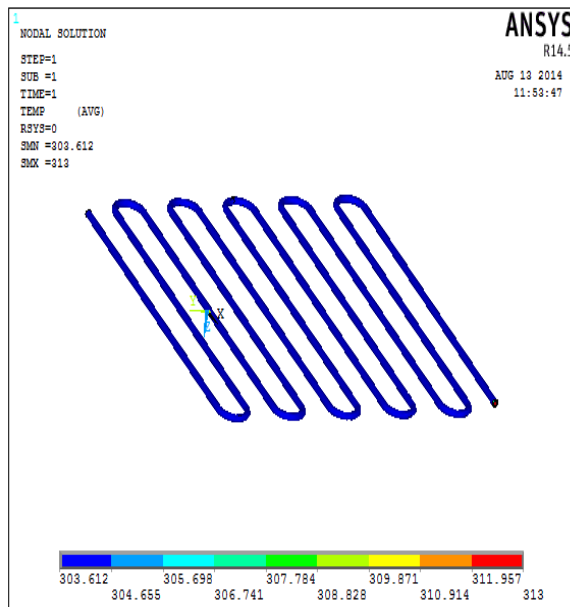

Thermal gradient>vector sum thermal gradient>ok

VI. RESULTS TABLE CONDENSER

MATERIALS		HCFC	404R	HFC-134A	HFC-152A
ALUMINUM	Nodal temperature (K)	313	313	313	313
	Thermal gradient (K/mm)	7.38409	3.91413	3.80315	3.87879
	Heat flux (W/mm ²)	1.115	0.821967	0.798829	0.814547
ALUMINUM ALLOY 6061	Nodal temperature (K)	313	313	313	313
	Thermal gradient (K/mm)	7.09002	3.96492	3.88289	3.93875
	Heat flux (W/mm ²)	1.4889	0.598703	0.586316	0.594751
COPPER	Nodal temperature (K)	313	313	313	313
	Thermal gradient (K/mm)	6.34488	3.77113	3.5878	3.71153
	Heat flux (W/mm ²)	2.44278	1.45188	1.38134	1.42894

COMPRESSOR

MATERIALS		HCFC	404R	HFC-134A	HFC-152A
ALUMINUM	Nodal temperature (K)	318	318	318	318
	Thermal gradient (K/mm)	18.6332	24.3464	21.623	23.3311
	Heat flux (W/mm ²)	3.91298	5.11273	4.54082	4.89952
ALUMINUM ALLOY 6061	Nodal temperature (K)	318	318	318	318
	Thermal gradient (K/mm)	20.4758	26.1693	23.4405	25.1662
	Heat flux (W/mm ²)	3.09289	3.95156	3.53951	3.8001
COPPER	Nodal temperature (K)	318	318	318	318
	Thermal gradient (K/mm)	15.6227	21.0092	18.4671	20.0439
	Heat flux (W/mm ²)	6.01476	8.08854	7.10983	7.71689

EVAPORATOR REESULTS

MATERIALS		HCFC	404R	HFC-134A	HFC-152A
ALUMINUM	Nodal temperature (K)	294.433	300.291	298.599	299.736
	Thermal gradient (K/mm)	25.6762	35.0324	32.2998	34.1237
	Heat flux (W/mm²)	5.39201	7.3568	6.78295	7.16597
ALUMINUM ALLOY 6061	Nodal temperature (K)	296.5967	301.106	299.799	300.685
	Thermal gradient (K/mm)	28.5967	36.3977	34.2274	35.6852
	Heat flux (W/mm²)	4.3181	5.49605	5.16833	5.38846
COPPER	Nodal temperature (K)	290.598	298.119	295.706	297.286
	Thermal gradient (K/mm)	19.7121	31.54	27.6889	30.2179
	Heat flux (W/mm²)	7.58914	12.1429	10.6602	11.6339

VII. CONCLUSION

In this thesis a compact model of house hold refrigerator, refrigeration system is designed and modeled in 3D modeling software Pro/Engineer. The refrigeration system consists of condenser, evaporator, compressor and expansion valve. The refrigerant used most nowadays is HFC-134a. In this thesis, it is replaced with HCFC, HFC-152A, 404R. The present used material is copper, in this thesis it is replaced with aluminum alloy 6061 and aluminum. Thermal analysis is done on the condenser, compressor and evaporator by changing the materials and refrigerants. Thermal analysis is done in Ansys. By observing the analysis results, thermal flux is more for copper but the density is more. So using copper, the components weight increases. When comparing both aluminum and aluminum alloy, thermal flux is more for Aluminum than aluminum alloy. When comparing the refrigerants, using 404R is better.

REFERENCES

- [1]. Recent Developments On Domestic Refrigerator-A Review By Abhishek Tiwari
- [2]. Energy Efficiency Improvements In Household Refrigeration Cooling Systems By Erik Björk
- [3]. Experimental Investigation Of A Domestic Refrigerator Having Water-Cooled Condenser Using Various Compressor Oils By Sreejith K
- [4]. Akash, B.A., Said, S.A., 2003. Assessment Of Lpg As A Possible Alternative To R-12 In Domestic Refrigerator. Energy Conversion Management 44, 381–388.
- [5]. Andrew Gigiel Safety Testing Of Domestic Refrigerators Using Flammable Refrigerants University Of Bristol Uk
- [6]. Arora, C.P., 2000. Refrigeration And Air Conditioning, 2nd Edition. Tata Mcgraw Hill Publishing Company Limited, New Delhi.
- [7]. B.O.Bolaji, University Of Agriculture, Nigeria.
- [8]. Calm, J.M., 2006. Comparative Efficiencies And Implications For Greenhouse Gas Emissions.
- [9]. Calm, J.M., Hourahan, G.C., 2001. Refrigerant Data Summery.
- [10]. Calm, J.M., Hourahan, G.C., 2001. Refrigerant Data Summery. Engineering Systems 18, 74–88.